



FUJII
ELECTRIC

ROOM AIR CONDITIONER

RM-13AP

SERVICE MANUAL

CONTENTS

SPECIFICATIONS	1
CIRCUIT DIAGRAM	2
DISASSEMBLY ILLUSTRATION	3
PARTS LIST	6



Большая библиотека технической документации

<https://splitsystema48.ru/instrukcii-po-ekspluatácii-kondicionerov.html>

каталоги, инструкции, сервисные мануалы, схемы.

SPECIFICATIONS

MODEL		RM-13AP
COOLING CAPACITY	(kW)	3.55

ELECTRICAL DATA

POWER SOURCE	(V)	220
FREQUENCY	(Hz)	50
RUNNING CURRENT	(A)	5.9
STARTING CURRENT	(A)	28
INPUT WATTS	(kW)	1.28
EER	(kW/kW)	2.77
FUSE	(A)	15

COMPRESSOR

TYPE		Hermetic type, Permanent split condenser, 2 pole, Single phase, Induction motor
CODE		QJ222PD23F 3 Leg 220 - 240V 50Hz
REFRIGERANT	R-22 (g)	890

FAN MOTOR

POWER SOURCE	(V)	220
HIGH	(r.p.m.)	950
LOW	(r.p.m.)	770

DIMENSIONS

H x W x D	(mm)	375 x 560 x 650
-----------	------	-----------------

WEIGHTS

GROSS / NET	(kg)	47 / 42
-------------	------	---------

MOISTURE REMOVAL	(l /hr)	1.4
------------------	-----------	-----

CIRCUIT DIAGRAM

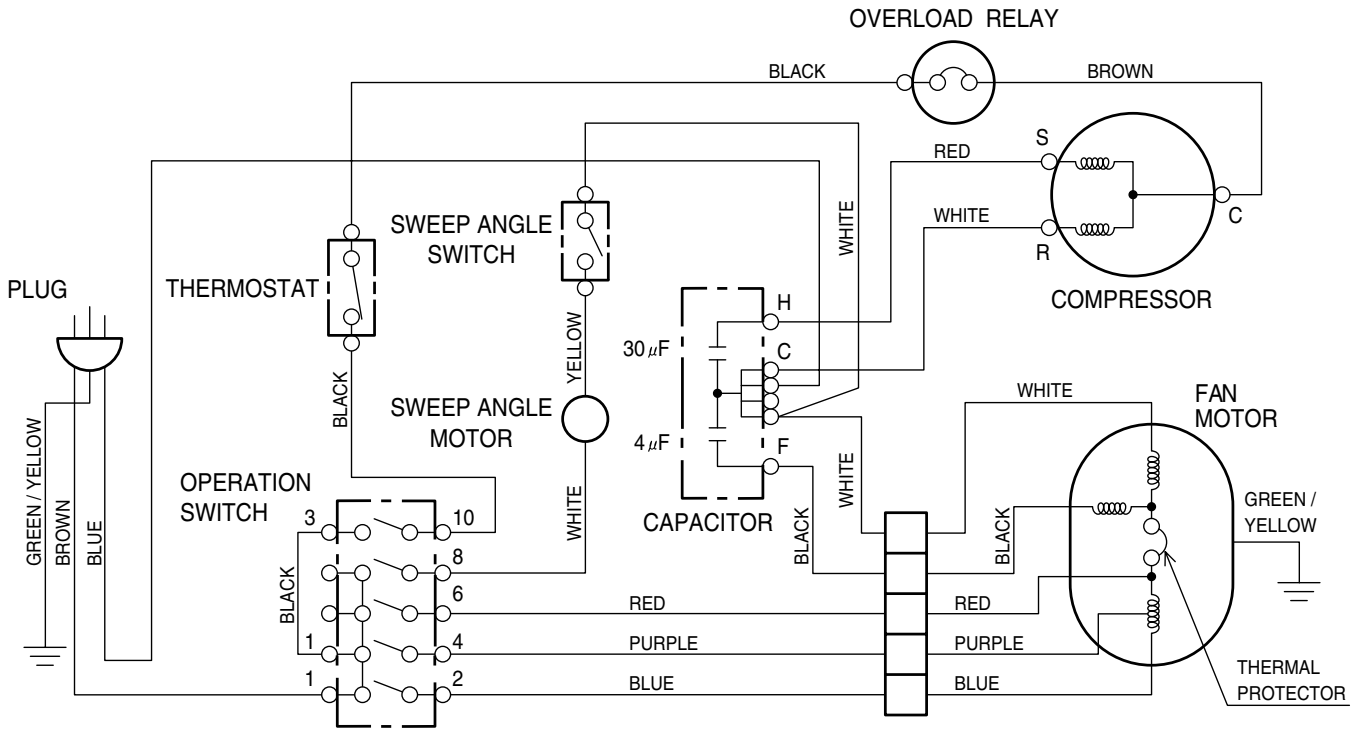

OPERATION SWITCH INTERNAL CONNECTIONS

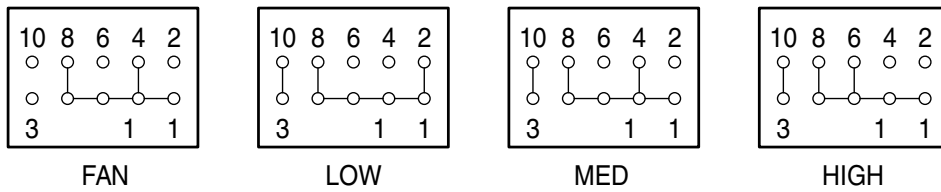

DISASSEMBLY ILLUSTRATION

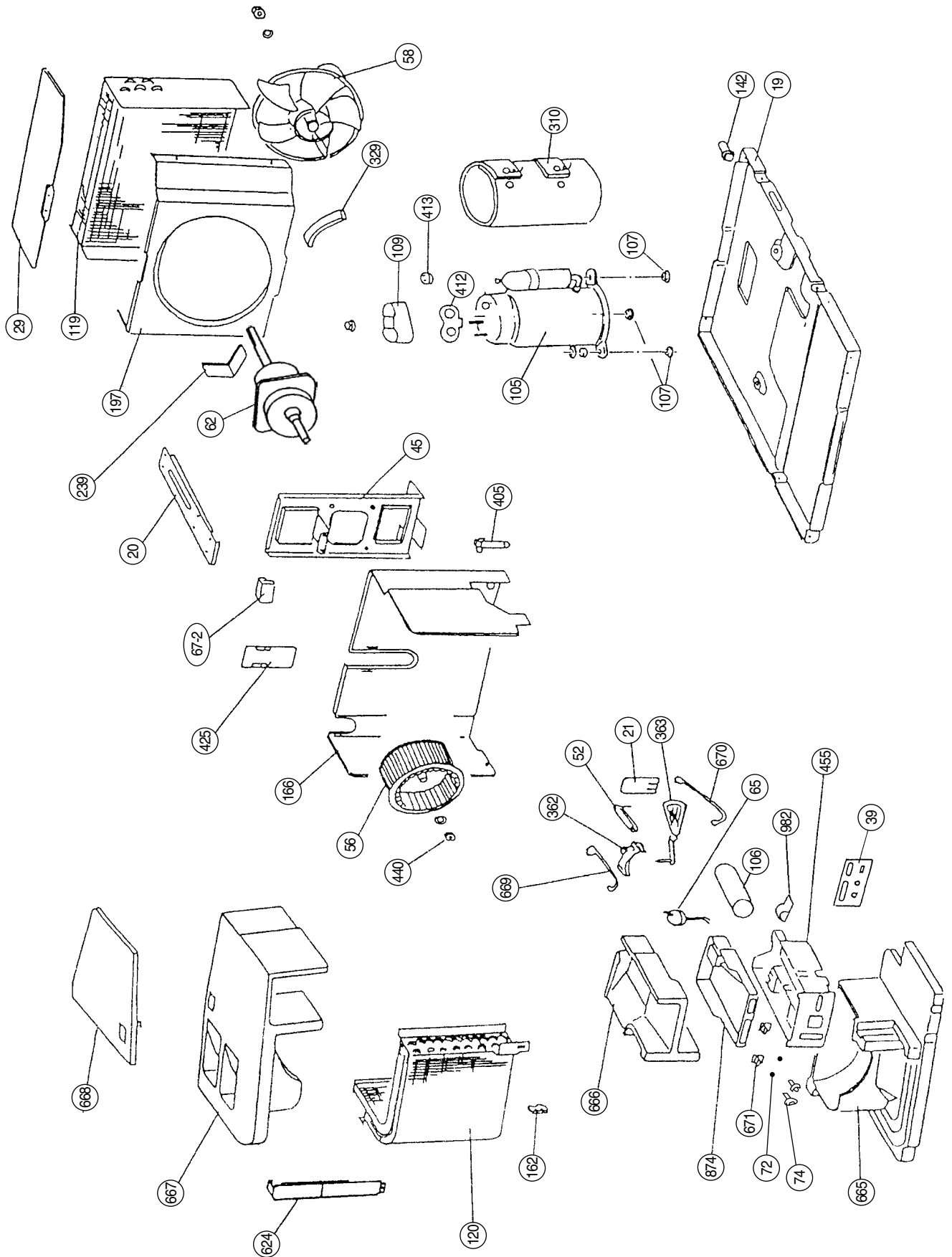

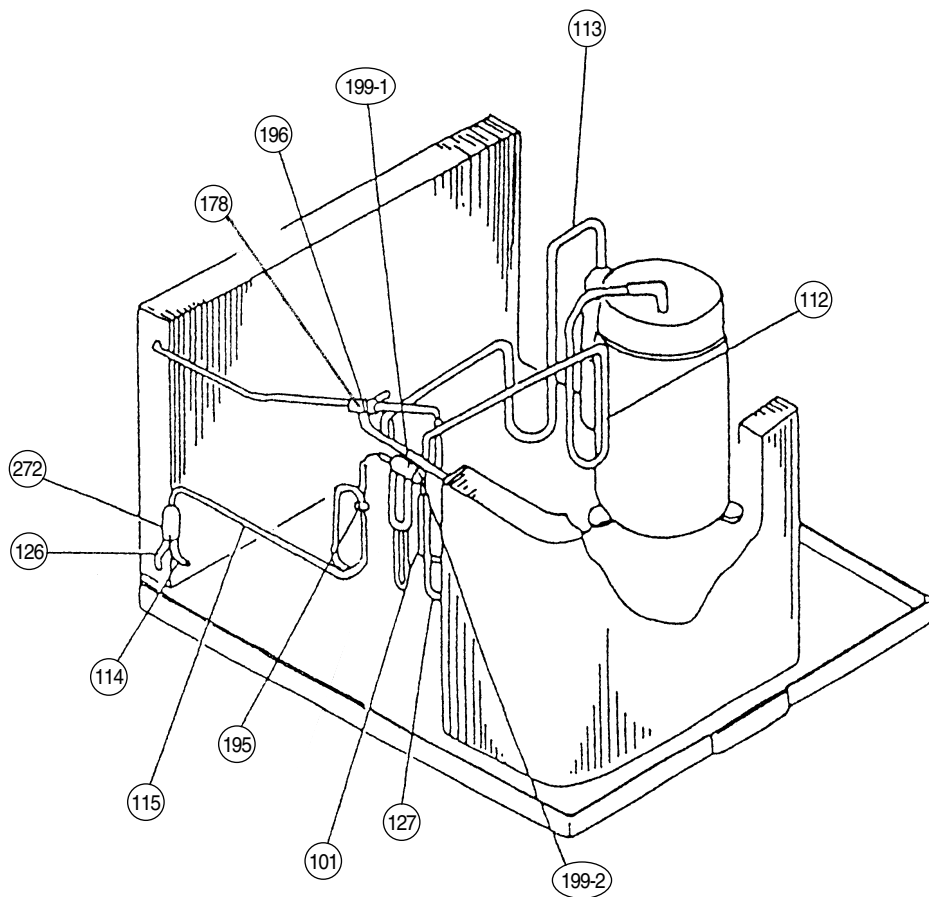
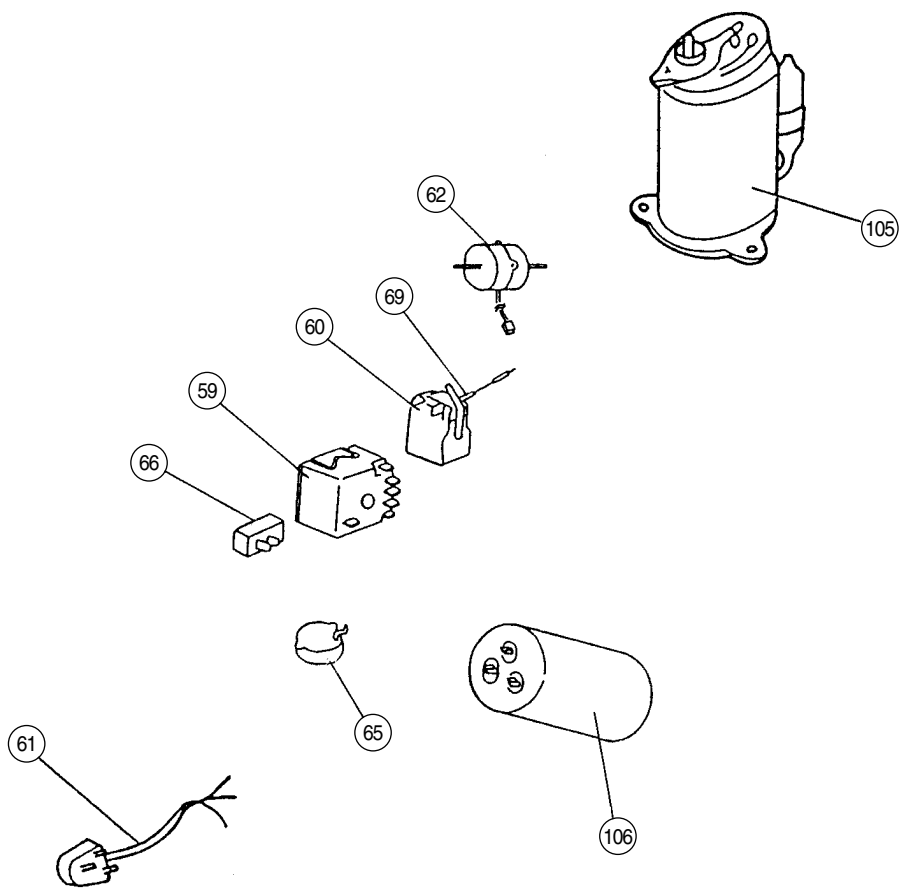

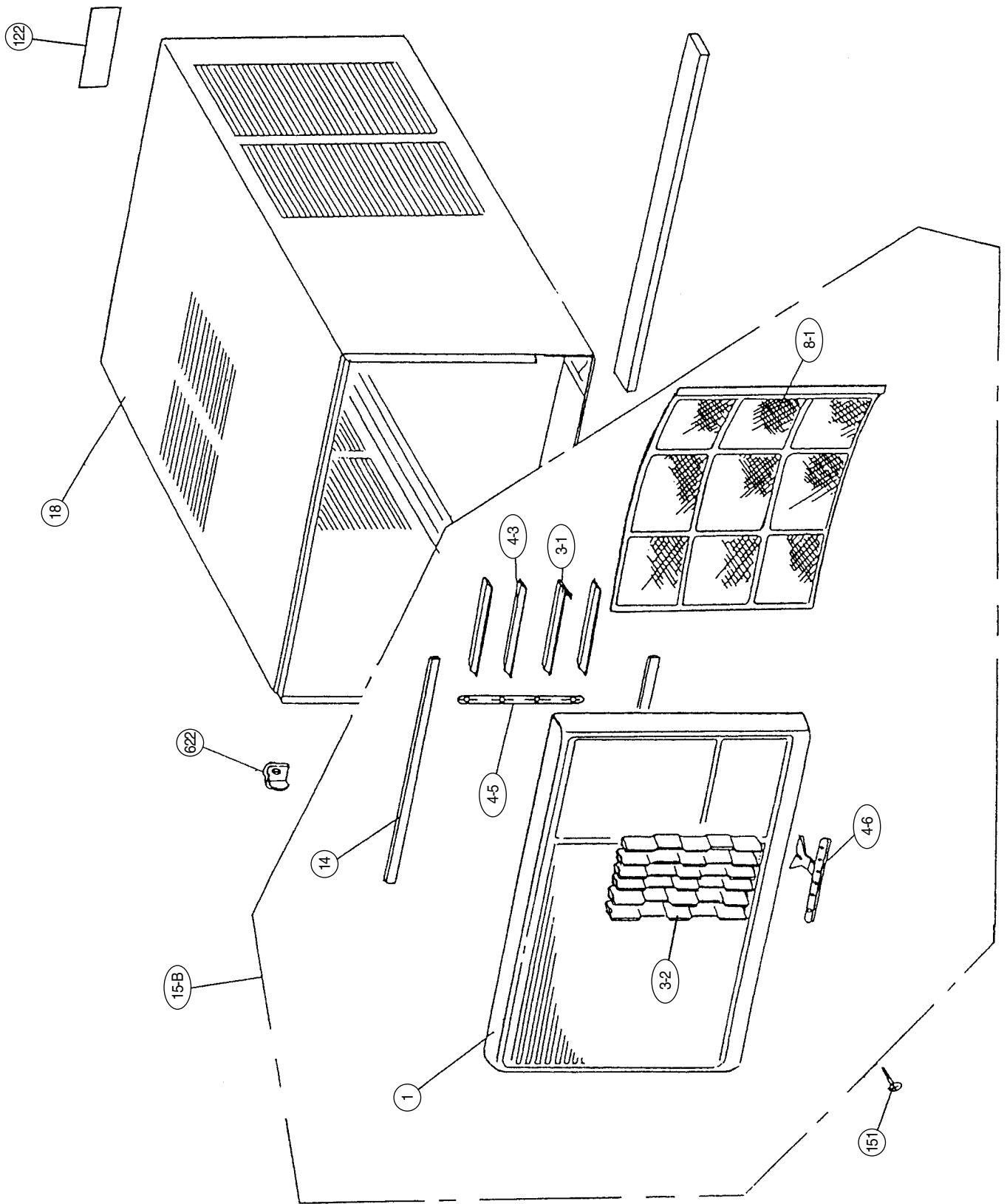

PARTS LIST

When you order parts, please make a photocopy of this page and fill the number of the parts in the "Order" column.

FRONT PANEL PARTS

Ref. No.	Description	Part No.	Ord. Q'ty	Ref. No.	Description	Part No.	Ord. Q'ty
1	Front Panel	9356309027		4-6	Connecting Plate-B	9356315004	
3-1	Louver-A	9356311006		8-1	Filter Assy	9356310023	
3-2	Louver-C	9356313017		14	Rail (Front Panel)	9356317015	
4-3	Louver-B	9356312003		15-B	Front Panel Assy	9356661118	
4-5	Connecting Plate-A	9356314007					

CABINET CHASSIS PARTS

Ref. No.	Description	Part No.	Ord. Q'ty	Ref. No.	Description	Part No.	Ord. Q'ty
18	Cabinet Assy	9356293012		142	Drain Pipe	9351746018	
19	Base Assy	9356288087		151	Front Panel Screw	313306389909	
20	Supporter-C	9356298000		162	Thermostat Holder	9356355000	
21	Exhaust Air Damper	9356336009		166	Separate Wall	9356294002	
29	Supporter-B	9356297003		178	Capillary Holder	313394274808	
39	Switch Panel	9362015004		195	Clamp SKB-100	313361275805	
45	Motor Fixing Table	9356299007		196	Clamp SKB-150	313035356905	
52	Louver Arm	313658122104		197	Wind Guide Board	9356295009	
56	Sirocco Fan Assy	9356350005		199-1	BR Sheet	313612108209	
58	Propeller Fan Assy	9356349009		199-2	BR Sheet	313816108200	
59	Operation Switch	9703097010		239	Water Seal Plate	9357196008	
60	Thermostat	9356666007		272	Strainer	9350203024	
61	Power Cord Assy	9703286049		310	Compressor Cover	9364186009	
62	Fan Motor Assy	9360721013		329	Sealant (Wind Guide Board)	9357223001	
65	Jet Vane Motor	9358032015		362	Guide Plate	9356337006	
66	Jet Vane Switch	9354272002		363	Moving Plate	9356338003	
67-2	Rubber-B (Vibration-proof)	9356354003		405	Clamp No. 1763	313816345304	
69	Protection Tube (Thermostat)	313310060308		412	Terminal Gasket (For Comp.)	9362004008	
72	Knob Spring(Thermostat Knob)	313008061010		413	Overload Relay	9363765007	
74	Operation Knob	9356352016		425	Separate Wall Cover	9356326000	
101	Inlet Pipe-A (Evaporator) Assy	9358000014		440	Special Nut	0700005084	
105	Compressor Assy	9363764000		455	Control Box	9356339017	
106	Running Capacitor	9354565234		622	Typhoon Lock	9356327007	
107	Rubber Seat-A (For Comp.)	9359425014		624	Reinforcement (Casing)-B	9356441000	
109	Terminal Cover (For Comp.)	9363263008		665	Casing-Under	9356330007	
112	Discharge Pipe	9365150009		666	Casing-Middle, Painted	9356329001	
113	Suction Pipe Assy	9364182018		667	Casing-Top, Painted	9356328004	
114	Air Duct Pipe-E	313252257206		668	Reinforcement (Casing)-C	9356296006	
115	Capillary Tube	9364185002		669	Operation Wire-A	9356333008	
119	Condenser Assy	9357701028		670	Operation Wire-B	9356334005	
120	Evaporator Assy	9356324013		671	Slide Lever	9356335019	
122	Emblem-B (Rear)	9352013000		874	Control Box Cover	9356332018	
126	Condensing Pipe	9356662009		982	Cord Clamp	9361129009	
127	Inlet Pipe-B (Evaporator) Assy	9358001011					



MANUFACTURER :

Fuji Denki Sosetsu Co., Ltd.

Tokyo, Japan



Большая библиотека технической документации

<https://splitsystema48.ru/instrukcii-po-ekspluatácii-kondicionerov.html>

каталоги, инструкции, сервисные мануалы, схемы.